

1021F

SPECIFICATIONS

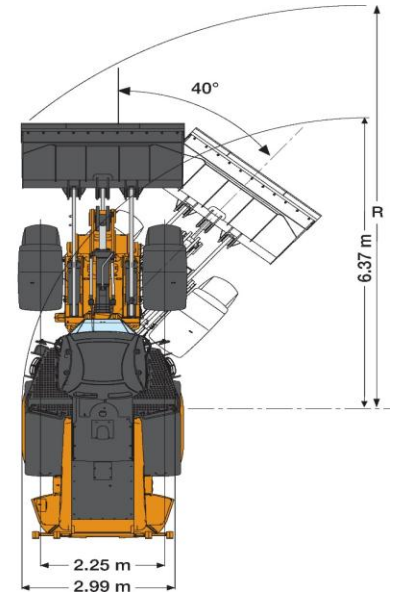

1021F GENERAL DIMENSIONS

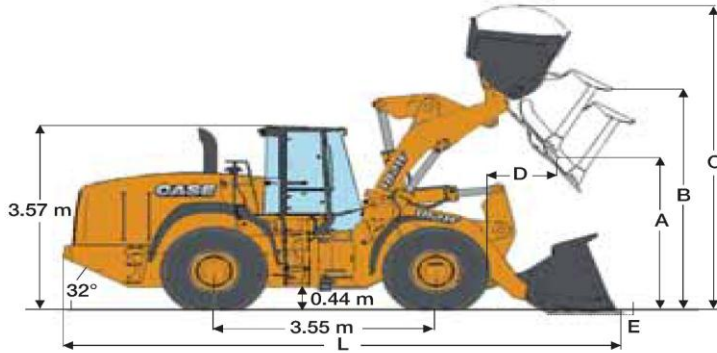

LOADER characteristics

Raising time (loaded)	sec	6.2
Dumping time (loaded)	sec	1.3
Lowering time (empty, power down)	sec	2.8
Lowering time (empty, float down)	sec	2.6

Bucket, standard with teeth	m ³	4.4
Volume at 110% fill factor	m ³	4.6
Bucket Payload	kg	8000
Maximum material density	ton/m ³	1.90

Tipping load - straight	kg	19219
Tipping load - articulated at 40°	kg	16018
Breakout force	kg	20963
Lift capacity from ground	kg	23479

A Dump height at 45° at full height	m	2.92
B Hinge pin height	m	4.24
C Overall height	m	5.94
D Bucket reach at full height	m	1.45
E Digging depth	cm	13
L Overall length	m	9.13
R Turning radius	m	7.10
Bucket rollback in carry position	°	49°
Dump angle at full height	°	53°
Machine operating weight	kg	25638

ENGINE 6 cylinder 8.7 litre turbocharged common rail

Maximum power @1800 rpm	hp	320
Maximum torque @1100 rpm	Nm	1479

TRANSMISSION 4 speed Powershift

Forward	km/h	4/38
Reverse	km/h	3/27

HYDRAULICS Rexroth

Maximum flow @2000rpm	l/m	352
-----------------------	-----	-----

AUXILIARY CIRCUIT

Max flow	l/m	260
Max pressure	Bar	224

Tyres (heavy duty)

26.5R25

SERVICE CAPACITIES

Fuel tank	l	459
Cooling system	l	57
Engine oil	l	26
Hydraulic oil tank	l	134
Total hydraulic system oil	l	250
Front and Rear Axles	l	68
Transmission oil	l	45

ROPS/FOPS cab with airconditioning